

DIMENSIONI D'INGOMBRO

POMPA	DIMENSIONI DI INGOMBRO																	PESO	
	DM _A	DN _M	A	B	C	E	F	H	I	L	M	N	P	Q	R	S	Z	COMPLETA	SOLO POMPA
PSOM15	65	40	---	548	---	350	---	180	205	---	623	230	403	320	123	60	14	118	---
PSO45	80	40	155	740	---	350	200	315	205	1050	650	960	450	300	295	85	22	305	150*
PSO50	80	40	155	740	---	350	200	315	205	1050	650	960	450	300	295	85	22	315	150*
PSO55	80	40	155	740	---	350	200	315	205	1050	650	960	450	300	295	85	22	315	150*
PSO75	80	70	182	780	235	512	200	315	240	310	652	570	950	860	153	115	22	415	185*

Dimensioni e pesi non impegnativi

* Peso per pompa senza motore, cinghie e pulegge, basamento e carter.

POMPA PSOM15

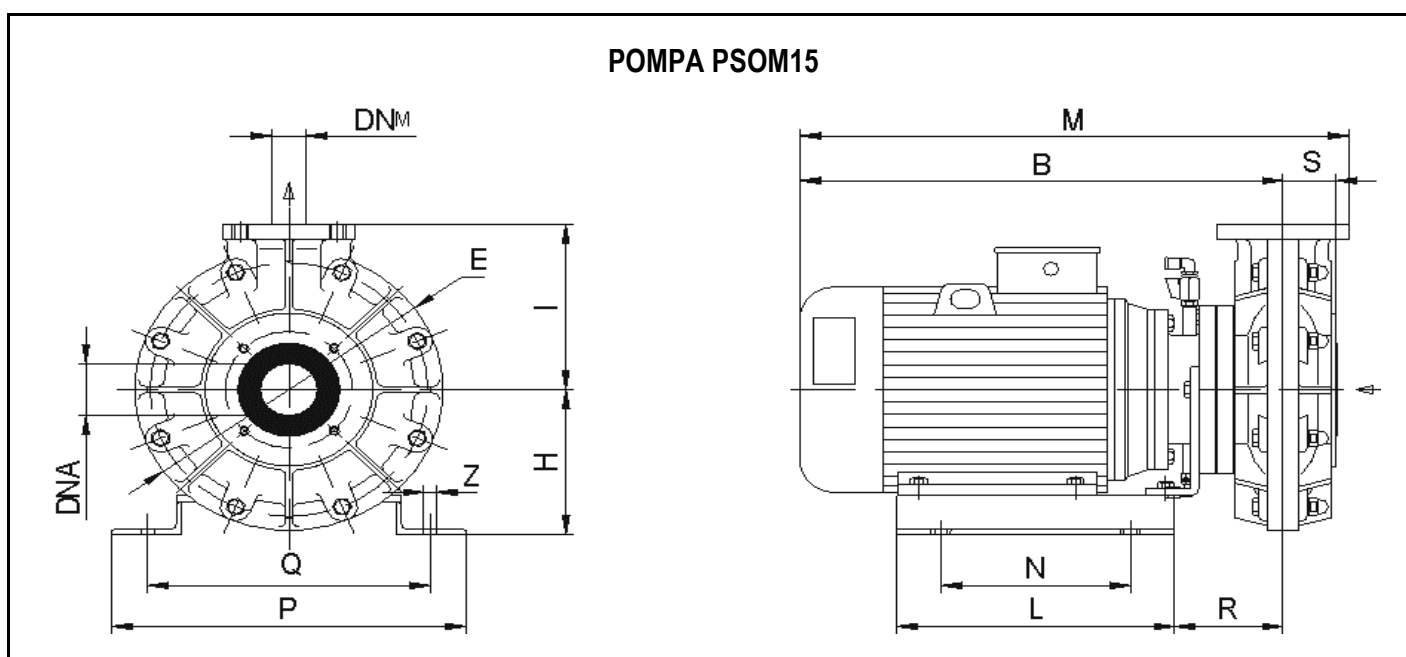

POMPA PSO45-50-55

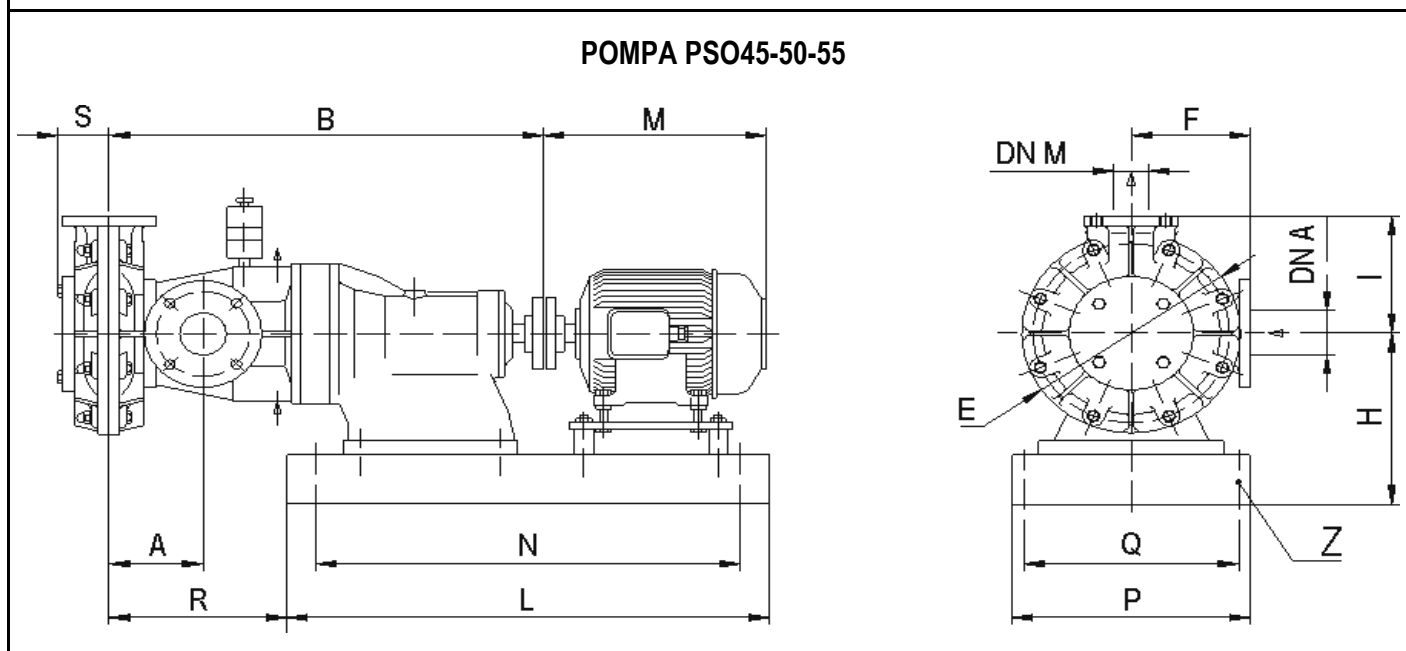

POMPA PS075

